

L12 - part 2
sec 1
31/7/2021

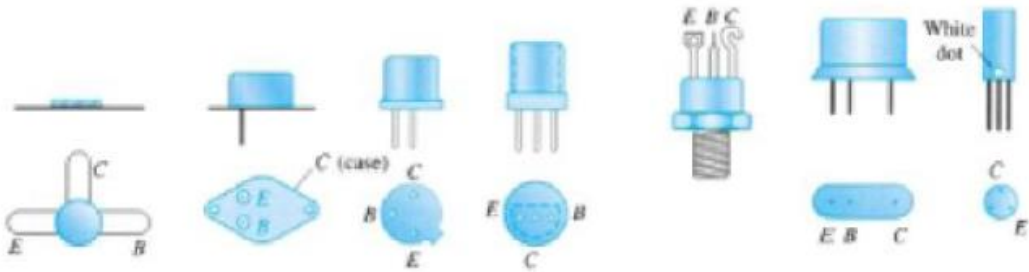

ENEE2360 Analog Electronics

T8:

BJT AC Models and Analysis

Instructor : Nasser Ismail

we will deal with small signal amplifiers in this course (not power amplifiers) X

Small Signal ac Equivalent Circuit

- In order to simplify the analysis, we replace the Transistor by an equivalent circuit (model)
- An AC model represents the AC characteristics of the transistor.
- A model uses circuit elements that approximate the behavior of the transistor.
- There are two models commonly used in small signal AC analysis of a transistor:
 - r_e model X
 - Hybrid equivalent model ** (h-parameter)

ENEE236

Two-port networks

- Suppose that a network N has two ports as shown below. How could it be represented or modeled?
- A common way to represent such a network is to use one of 6 possible *two-port networks*.
- These networks are circuits that are based on one of 6 possible sets of *two-port equations*. These equations are simply different combinations of two equations that relate the variables V_1 , V_2 , I_1 , and I_2 to one another. The coefficients in these equations are referred to as *two-port parameters*.

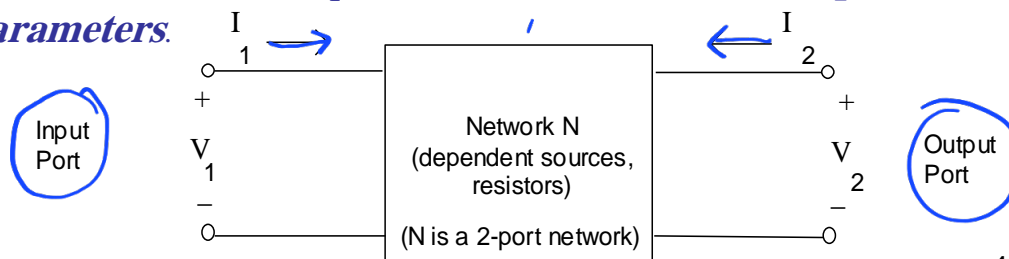

4

ENEE234 – Circuit Analysis

Note that I_1 , I_2 , V_1 , and V_2 are labeled as shown by convention. Often there is a common negative terminal between the input and the output so the figure above could be redrawn as:

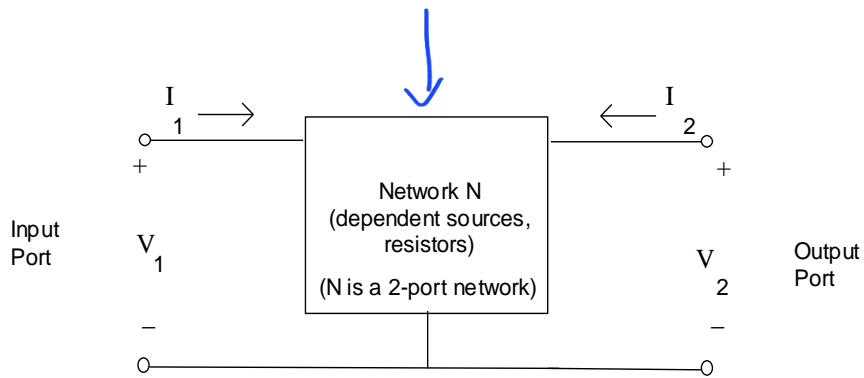

ENEE236

Development of the h-parameter model of BJT:

For A BJT the equivalent h parameter model can be described by the following equations:

h - parameter equations :

$$V_1 = h_i \cdot I_1 + h_r \cdot V_2 \quad \leftarrow \text{KVL}$$

$$I_2 = h_f \cdot I_1 + h_o \cdot V_2 \quad \leftarrow \text{KCL}$$

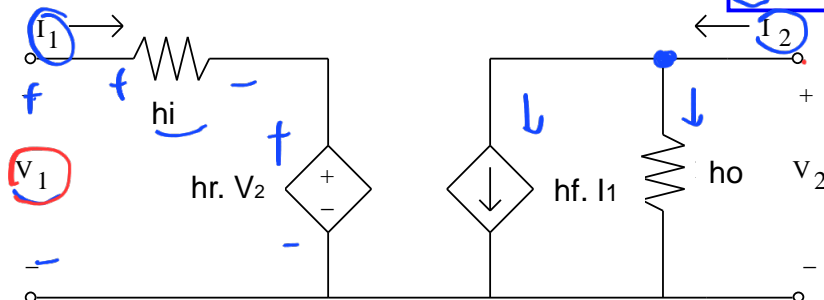

$$h_i = \left. \frac{V_1}{I_1} \right|_{V_2=0}$$

$$h_r = \left. \frac{V_1}{V_2} \right|_{I_1=0}$$

$$h_f = \left. \frac{I_2}{I_1} \right|_{V_2=0}$$

$$h_o = \left. \frac{I_2}{V_2} \right|_{I_1=0}$$

test $V_2=0$

$$V_1 = h_i I_1 + h_r V_2$$

$$h_i = \frac{V_1}{I_1} \quad V_2=0$$

$$h_f = \frac{I_2}{I_1} \quad V_2=0$$

$$I_2 = h_f I_1 + h_o V_2$$

7

ENEE236

Summary:

Note: This page is for information only

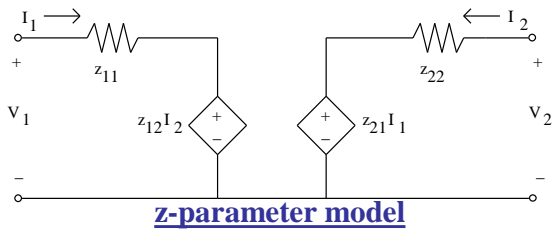

z - parameter equations :

$$V_1 = z_{11} \cdot I_1 + z_{12} \cdot I_2$$

$$V_2 = z_{21} \cdot I_1 + z_{22} \cdot I_2$$

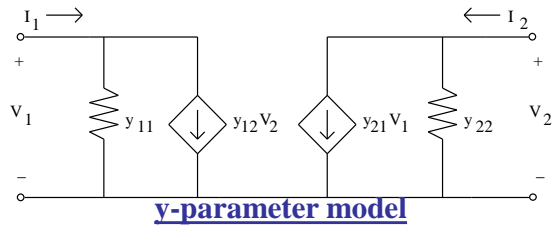

y - parameter equations :

$$I_1 = y_{11} \cdot V_1 + y_{12} \cdot V_2$$

$$I_2 = y_{21} \cdot V_1 + y_{22} \cdot V_2$$

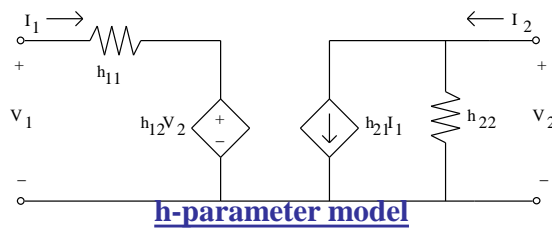

h - parameter equations :

$$V_1 = h_{11} \cdot I_1 + h_{12} \cdot V_2$$

$$I_2 = h_{21} \cdot I_1 + h_{22} \cdot V_2$$

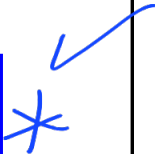

BJT Configurations

Amplifiers

- Common Emitter → CE
- Common Base → CB
- Common Collector → CC

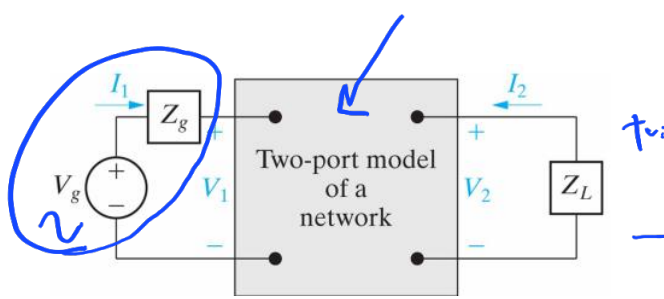
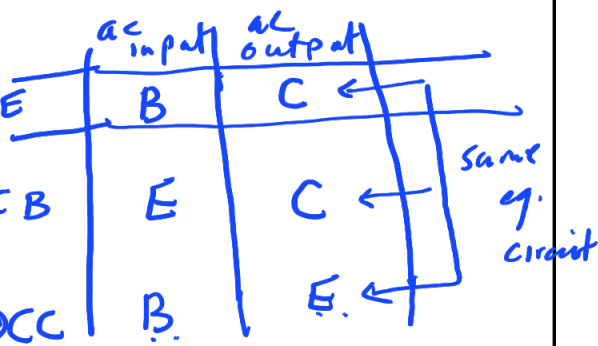

Terminated Two port network
 Includes source and load

End of L12 - part 2
 31/7/2021

L13 1/8/2021
CE & CC
 $h_i \rightarrow h_{ie}$
 $h_r \rightarrow h_{re}$
 $h_f \rightarrow h_{fe}$
 $h_o \rightarrow h_{oe}$

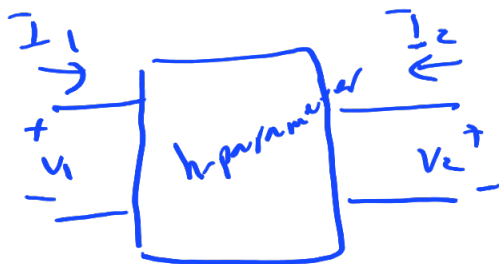

Common Emitter Configuration

(inverting configuration, provides voltage and current gain)

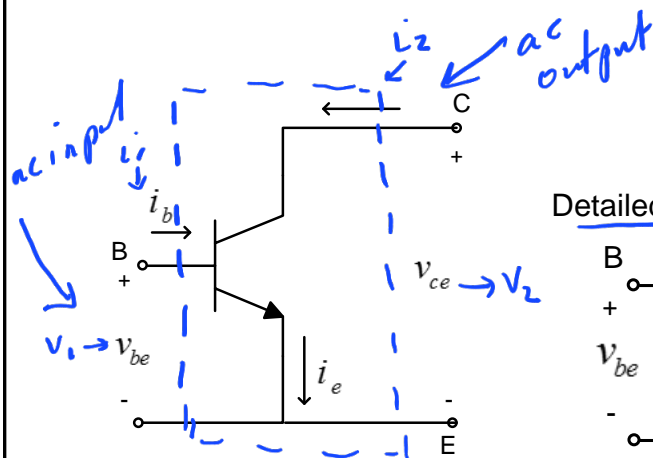

h - parameter equations:

$$V_{be} = h_{ie} \cdot I_b + h_{re} \cdot V_{ce}$$

$$I_c = h_{fe} \cdot I_b + h_{oe} \cdot V_{ce}$$

Detailed Model

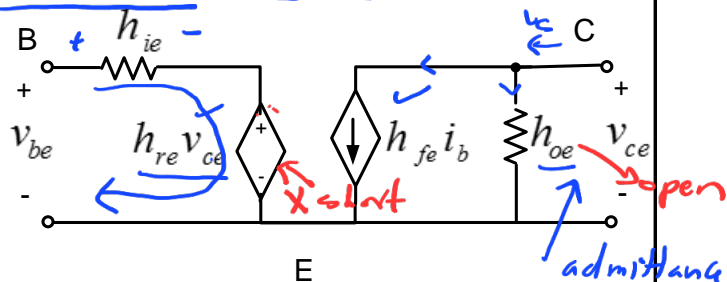

Simplified Model **

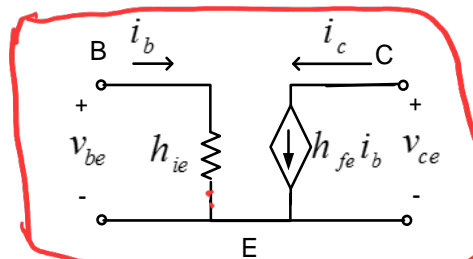

Typical Data sheet parameter values

$$h_{ie} \approx 1600 \Omega$$

$$h_{re} \approx 0.0002$$

$$h_{fe} \approx 80$$

$$h_{oe} \approx 20 \cdot 10^{-6} \text{ Siemens}$$

$\frac{1}{\Omega}$

ac equivalent circuit

Common Emitter and Common Collector Configuration

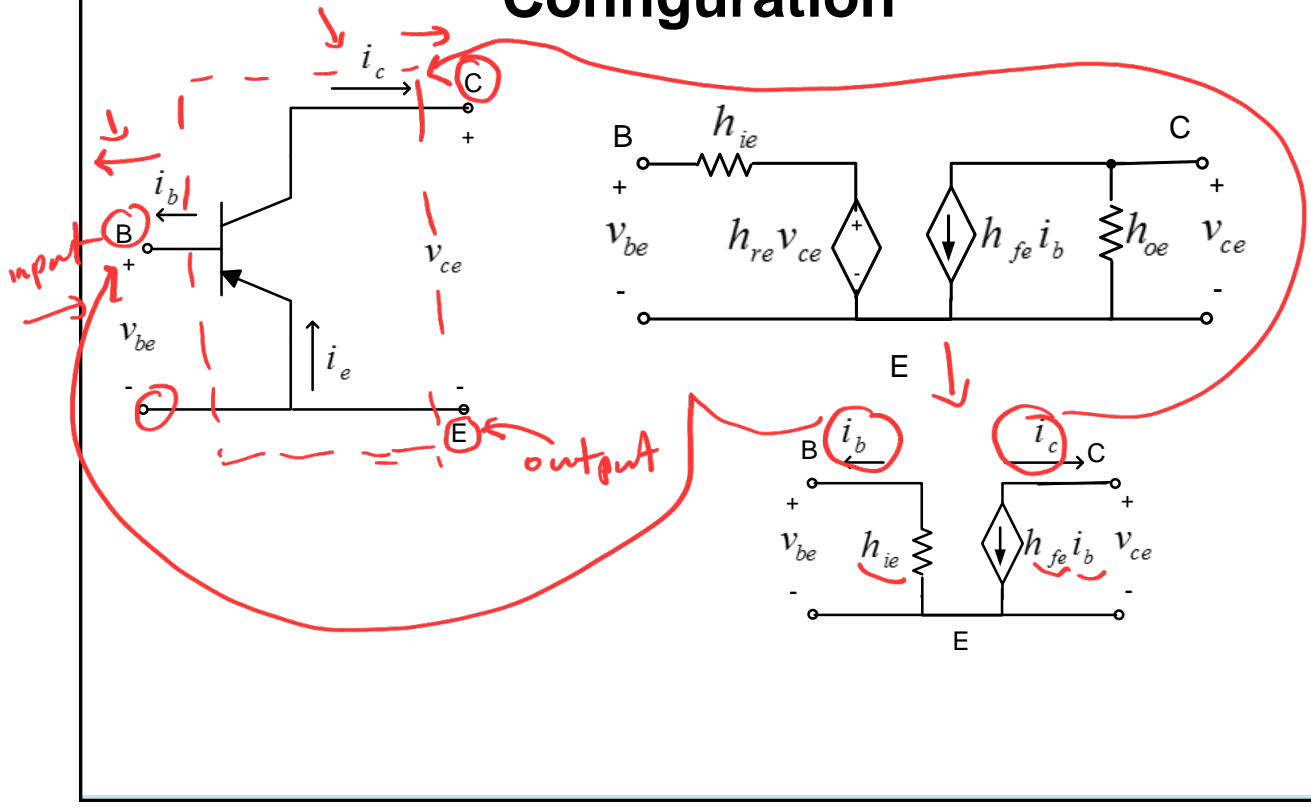

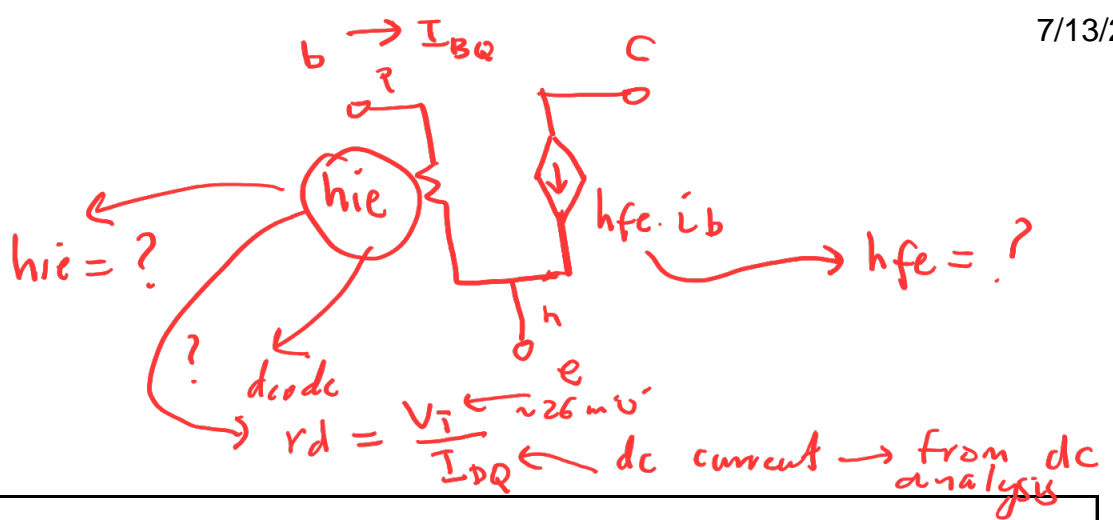

Value of h_{ie} → Found from dc analysis

Base Emitter is a pn junction similar to a diode
h_{ie} is the dynamic resistance of the pn junction

In a diode:

$$h_{fe} = \frac{i_c}{i_b} = \beta$$

$$r_d = \frac{V_T}{I_{DQ}} \Rightarrow$$

$$h_{ie} = \frac{V_T}{I_{BQ}} = \frac{V_T}{\frac{I_{CQ}}{h_{fe}}} = \frac{h_{fe} V_T}{I_{CQ}}$$

I_{BQ} dc value of base current

I_{CQ} dc value of collector current

$$h_{fe} = \beta$$

$$V_T = 25.69 \text{ mV @ } 25 \text{ }^\circ\text{C}$$

Common Collector

(provides current gain and no voltage gain)

Same Model of Common Emitter will be used due to the similarities between them and for simplicity

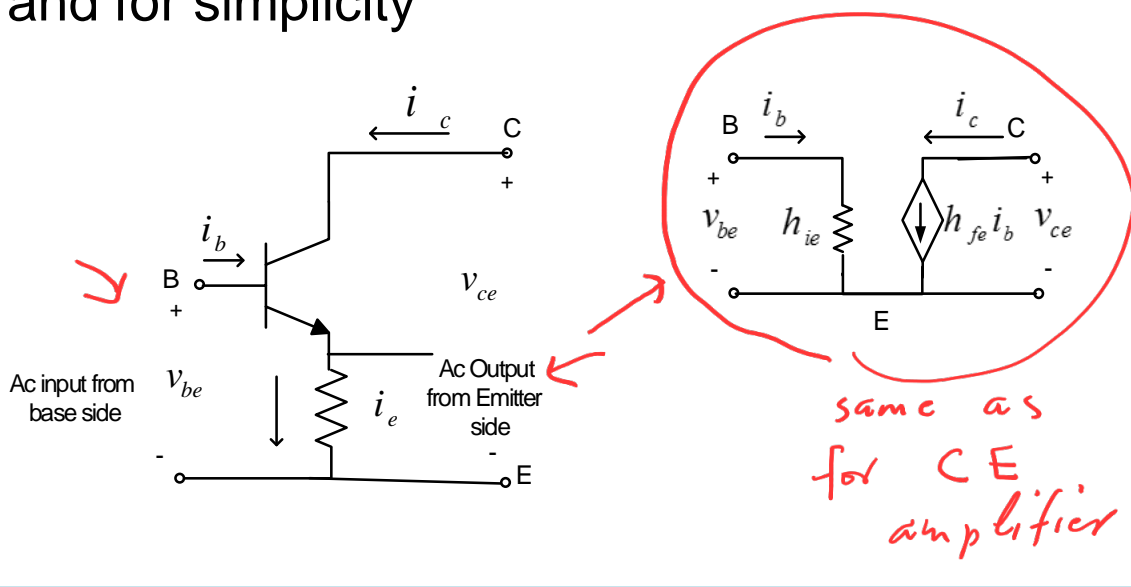

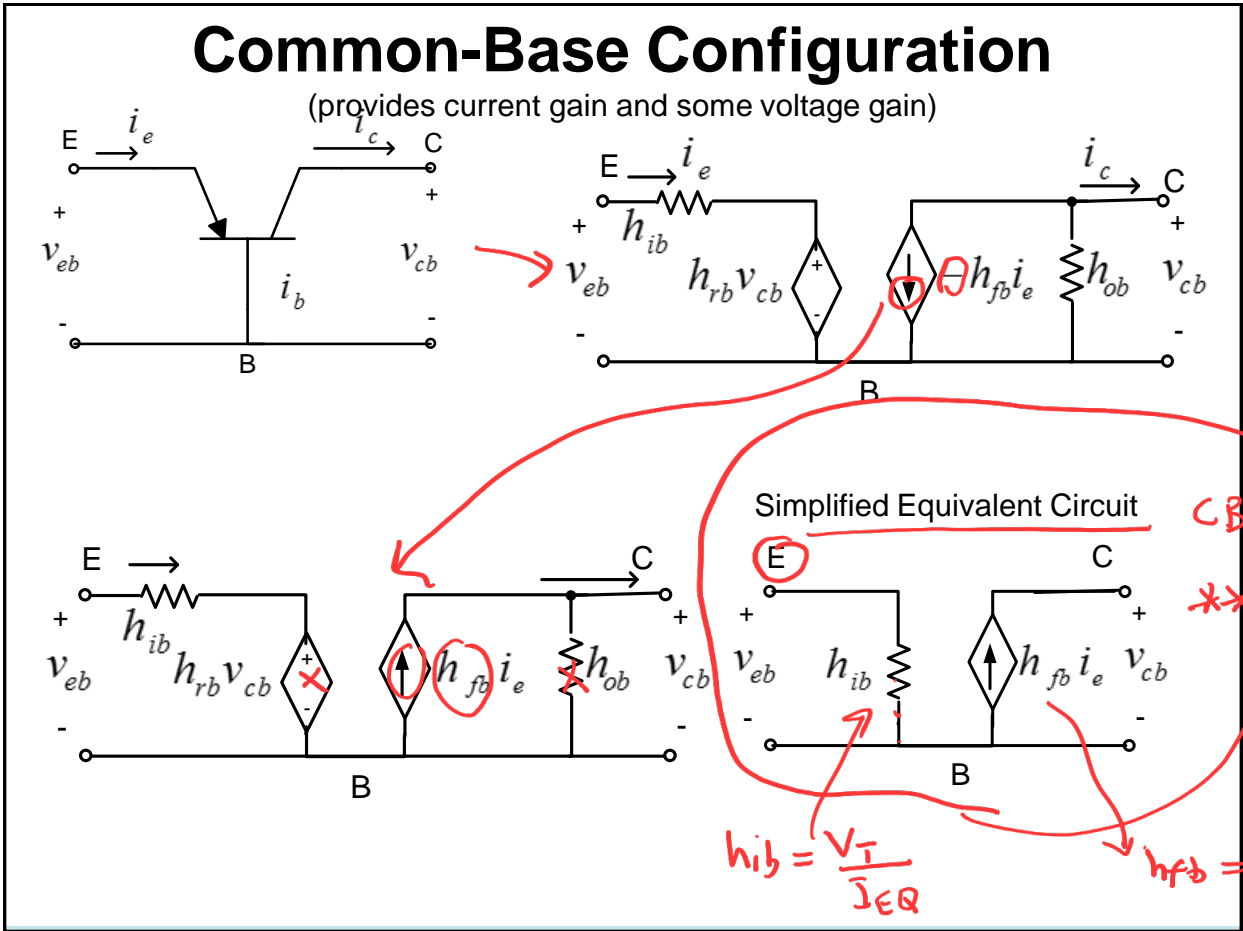

Common-Base Configuration

$$h_{ib} = \frac{V_T}{I_{EQ}} \quad \checkmark$$

$$h_{fb} = \alpha \quad \checkmark$$

$$V_T = 25.69 \text{ mV @ } 25^\circ\text{C}$$

$$h_{ie} > h_{ib}$$

$$h_{ie} = \frac{V_T}{I_{BQ}}$$

$$h_{ie} = \frac{V_T}{\frac{I_E}{\beta+1}}$$

$$h_{ie} = \frac{V_T (\beta+1)}{I_E}$$

$$h_{ie} = h_{ib} (\beta+1)$$

BJT Amplifier Analysis

When Analyzing Amplifier Circuits, we usually want to find some or all of the following quantities with and without R_s :

- 1) $A_v = V_o/V_i$, small signal voltage gain
- 2) $A_i = i_o/i_i$, small signal current gain
- 3) Z_i Input Impedance
- 4) Z_o Output Impedance

$A_v = \frac{V_o}{V_i}$

(Handwritten notes: $V_o \leftarrow ac$, $V_i \leftarrow ac$)

ac small signal (SS) quantities

to be given

to be given

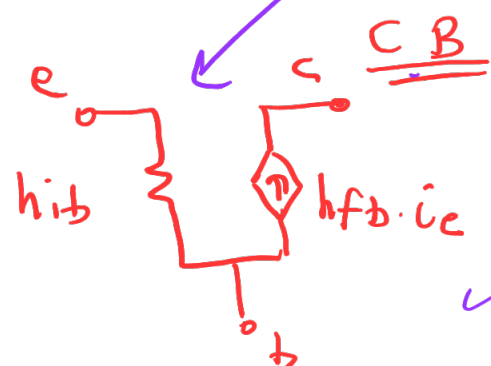
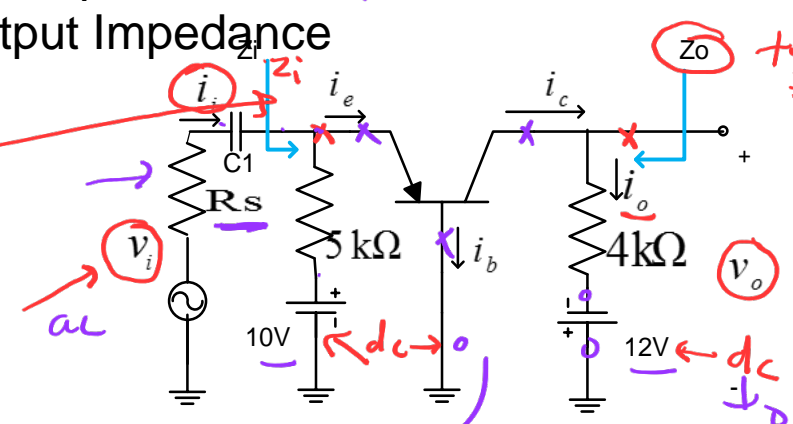

- ac analysis $\rightarrow f \uparrow \uparrow$ large
- all dc sources are killed (deactivated)
 - $V \rightarrow 0 \rightarrow$ short
 - $I \rightarrow 0 \rightarrow$ open
 - Caps $\rightarrow X_C = \frac{1}{2\pi f C}$
 $X_C \cong 0 \rightarrow$ are replaced by short circuit

BJT Amplifier Analysis

Solution: (with $R_s=0$)

We draw the ac small signal equivalent circuit

Capacitors \Rightarrow replaced by short circuit

DC sources are killed ,

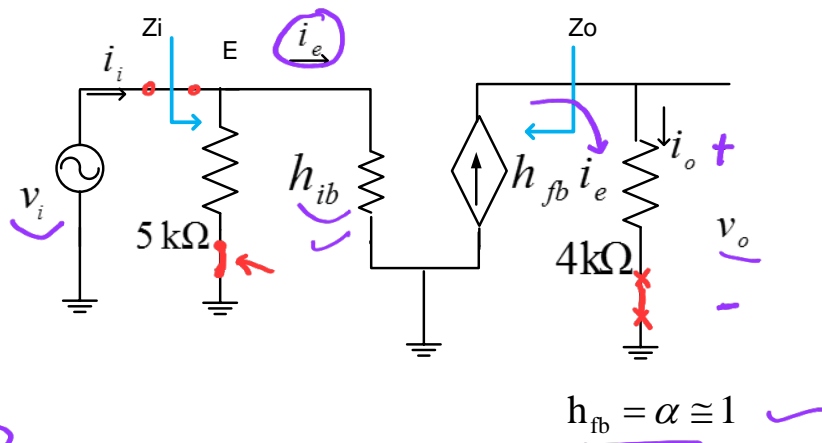

$$h_{ib} = \frac{V_T}{I_{EQ}}$$

I_{EQ} must be calculated from DC analysis

$$h_{fb} = \alpha \cong 1$$

$A_v = \frac{V_o}{V_i}$

$V_o = i_o \cdot 4k \rightarrow \frac{V_o}{i_o} = 4k$ ①
 $i_o = h_{fb} \cdot i_e \rightarrow \frac{i_o}{i_e} = h_{fb}$ ②
 $i_e = \frac{V_i}{h_{ib}} \rightarrow \frac{i_e}{V_i} = \frac{1}{h_{ib}}$ ③

$\text{①} \times \text{②} \times \text{③} = \frac{V_o}{i_o} \times \frac{i_o}{i_e} \times \frac{i_e}{V_i} = \frac{V_o}{V_i} = A_v$
 $A_v = 4k \times h_{fb} \times \frac{1}{h_{ib}}$

$$A_v = 4k \cdot h_{fb} \cdot \frac{1}{h_{ib}}$$

$$h_{ib} = \frac{V_T}{I_{EQ}}$$

dc current
→ dc analysis

DC Analysis

DC Equivalent Circuit:
-Cap ==> open
-Kill ac sources ==>

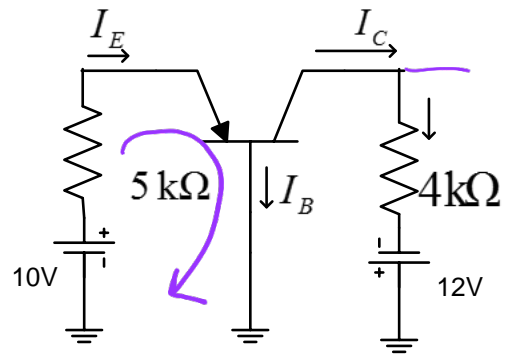

$$10 = 5 \text{ k}\Omega \cdot I_{EQ} + V_{EB}$$

$$I_{EQ} = \frac{10 - 0.7}{5 \text{ k}\Omega} = 1.86 \text{ mA}$$

$$h_{ib} = \frac{V_T}{I_{EQ}} = \frac{25.69 \text{ mV}}{1.86 \text{ mA}} = 13.98 \Omega$$

Ac ss equivalent circuit

$$1) A_V = \frac{v_o}{v_i}$$

$$v_o = i_o \cdot 4 \text{ k}\Omega$$

$$i_o = h_{fb} \cdot i_e$$

$$i_e = \frac{v_i}{h_{ib}}$$

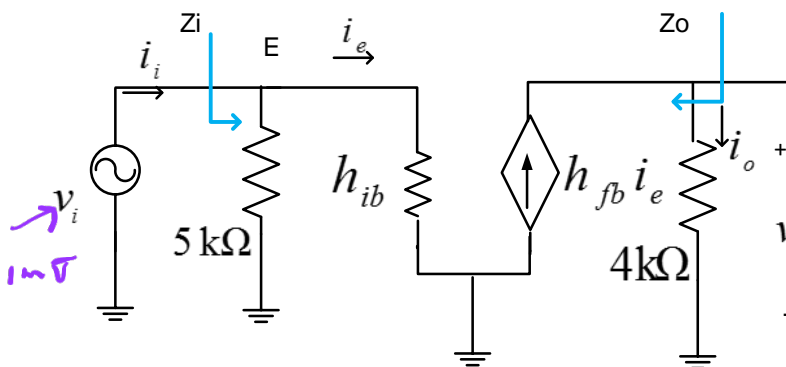

$$A_V = \frac{v_o}{v_i} = \frac{v_o}{i_o} \cdot \frac{i_o}{i_e} \cdot \frac{i_e}{v_i}$$



$$A_V = (4 \text{ k}\Omega) \cdot (h_{fb}) \cdot \left(\frac{1}{h_{ib}} \right)$$

$$= (4 \text{ k}\Omega) \cdot (1) \cdot \left(\frac{1}{13.98} \right) = 286 > 1$$

↑
voltage gain

286v

Current Gain Ai

$$2) A_i = \frac{i_o}{i_i}$$

$$i_o = h_{fb} \cdot i_e$$

$$i_e = i_i \frac{5 \text{ k}\Omega}{5 \text{ k}\Omega + h_{ib}}$$

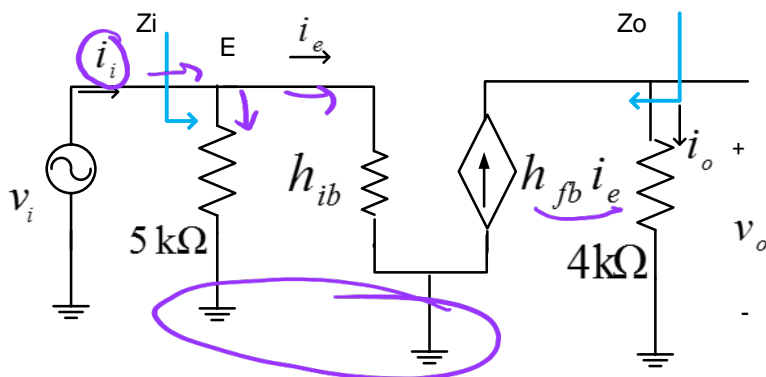

$$\Rightarrow A_i = \frac{i_o}{i_i} = \frac{i_o}{i_e} \cdot \frac{i_e}{i_i}$$

$$\Rightarrow A_i = (h_{fb}) \left(\frac{5 \text{ k}\Omega}{5 \text{ k}\Omega + h_{ib}} \right)$$

$$= (1) \left(\frac{5 \text{ k}\Omega}{5 \text{ k}\Omega + 13.98} \right) < 1$$

End of L13
2/8/2021

BJT Amplifier Configurations

L14 1sec
4-8-2021

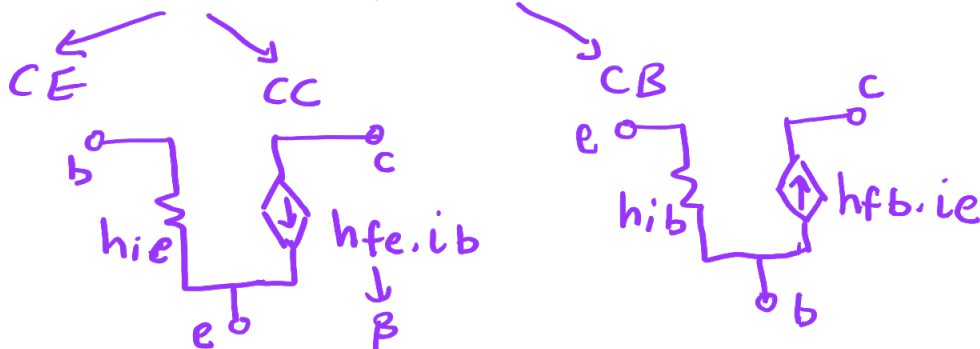

ac
ss
eq.
circuit

Zi & Zo

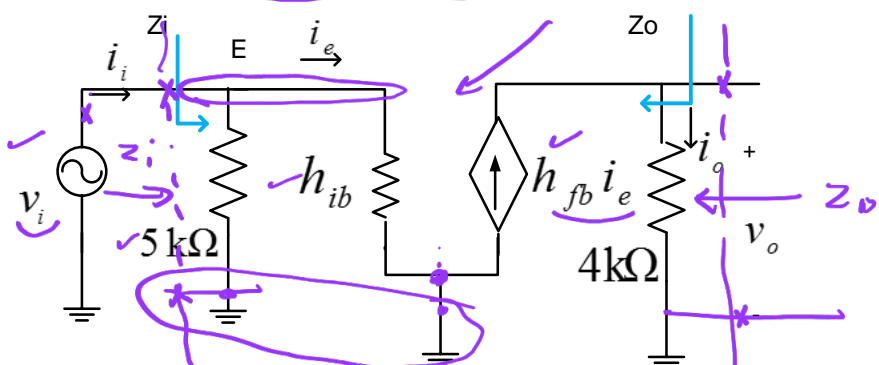

3) Input Impedance

$$Z_i = (h_{ib} // 5 \text{ k}\Omega) = \left(\frac{h_{ib} \cdot 5 \text{ k}\Omega}{5 \text{ k}\Omega + h_{ib}} \right)$$

4) Output Impedance

$$Z_o \Big|_{\text{all independent sources killed (i.e. } V_i=0 \text{ or short)}} = \underline{\underline{4 \text{ k}\Omega}}$$

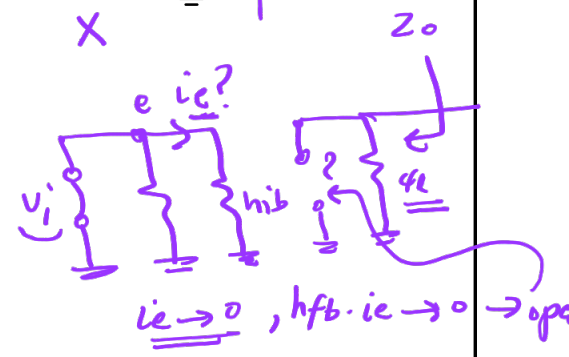

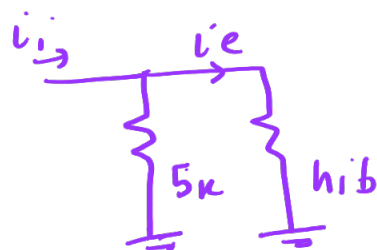
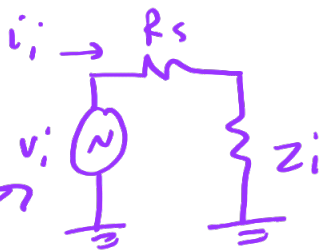

$$i_e = i_i \times \frac{5k}{5k + h_{ib}}$$

With Presence of R_s

with R_s

$$i_i = \frac{v_i}{Z_i + R_s}$$

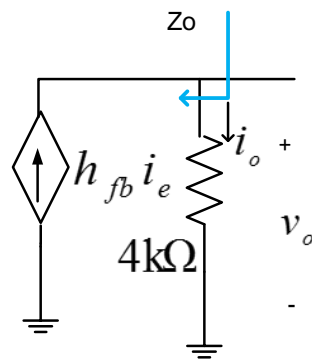
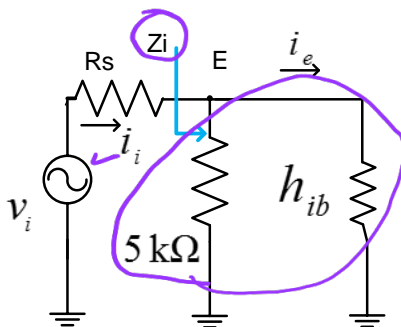

For $R_s = 50 \Omega$

$A_v = 62.5$ ←

For $R_s = 10 k\Omega$

$A_v = 0.4$ ←

$R_s = 0 \rightarrow A_v = 286$

↑ $R_s \rightarrow A_v ?$ ↓



$\frac{V_o}{V_i} \leftarrow A_v$ Z_i ✓
 $\frac{V_o}{I_i} \leftarrow A_i$ Z_o ✓

Example: Common Emitter (CE)

1) From DC Analysis,
we find Q - point and value of

$$h_{ie} = \frac{V_T}{I_{BQ}}$$

Handwritten notes: h_{ie} is the input resistance, I_{BQ} is the DC base current, and V_T is the thermal voltage. A small circuit diagram shows a base-emitter junction with a current source I_{BQ} and a voltage V_T .

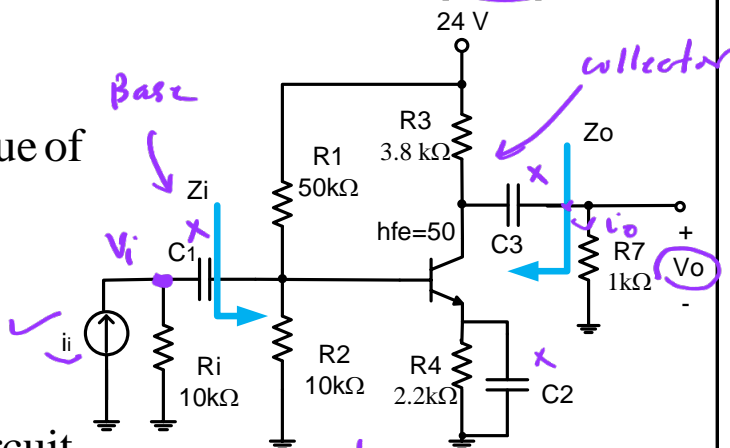

Thevenin's equivalent circuit
as seen from the base

$$V_{TH} = \frac{10 \text{ k}\Omega}{10 \text{ k}\Omega + 50 \text{ k}\Omega} \cdot 24 \text{ V} = 4 \text{ V}$$

$$R_{TH} = 10 \text{ k}\Omega // 50 \text{ k}\Omega = 8.33 \text{ k}\Omega$$

Handwritten: dc eq. circuit

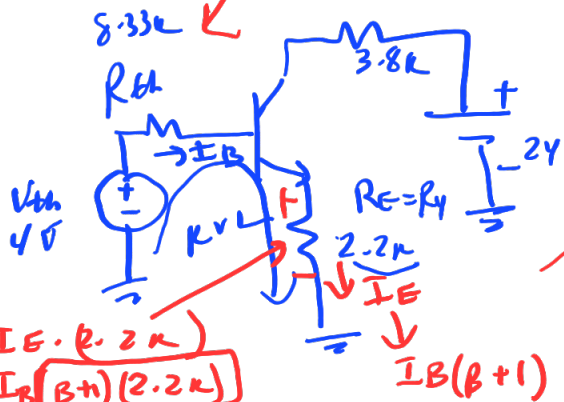
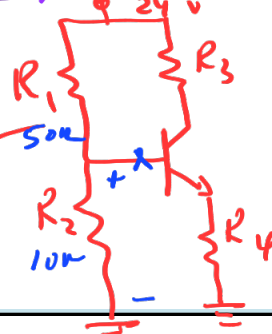

$$I_B = \frac{V_{th} - 0.7}{R_{th} + R_E(\beta + 1)}$$

$$= \frac{4 - 0.7}{8.33 \text{ k} + 2.2 \text{ k}(50 + 1)}$$

* Base equivalent circuit

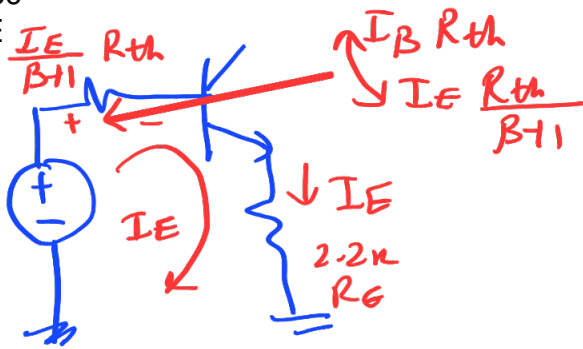

$$I_E = \frac{V_{th} - 0.7}{R_E + \frac{R_{th}}{\beta + 1}}$$

* Emitter equivalent circuit

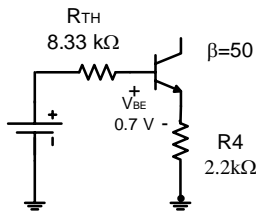

$$4 = 8.33 \text{ k}\Omega \cdot I_B + V_{BE} + 2.2 \text{ k}\Omega \cdot I_E$$

But, $I_E = (1 + \beta)I_B$

$$\text{Solve for } I_E = \frac{4 - 0.7}{\frac{8.33 \text{ k}\Omega}{(1 + 50)} + 2.2 \text{ k}\Omega} = 1.4 \text{ mA}$$

$$h_{ie} = \frac{V_T}{I_{BQ}} = \frac{25.69 \text{ mV}}{\frac{1.4 \text{ mA}}{51}} = 928 \Omega$$

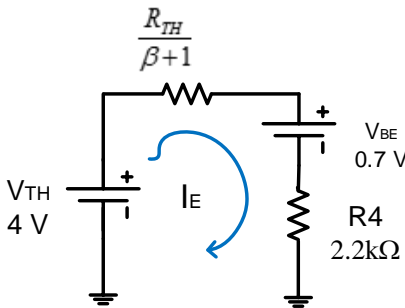

Here we have base reflected to emitter

$$I_B \Rightarrow I_E = (\beta + 1)I_B$$

$$R_B \Rightarrow \frac{R_B}{\beta + 1}$$

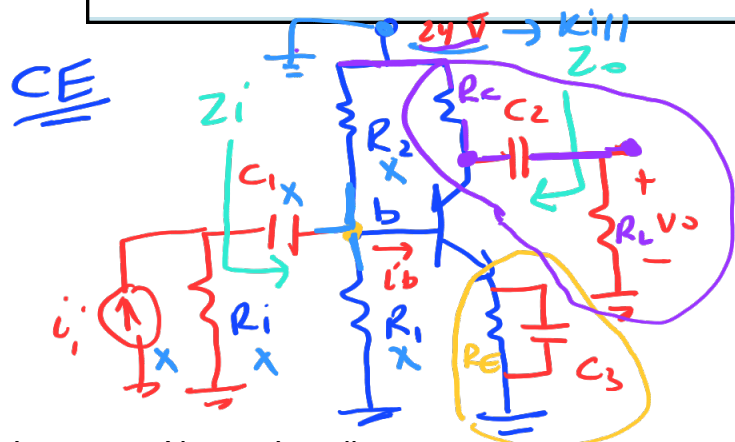
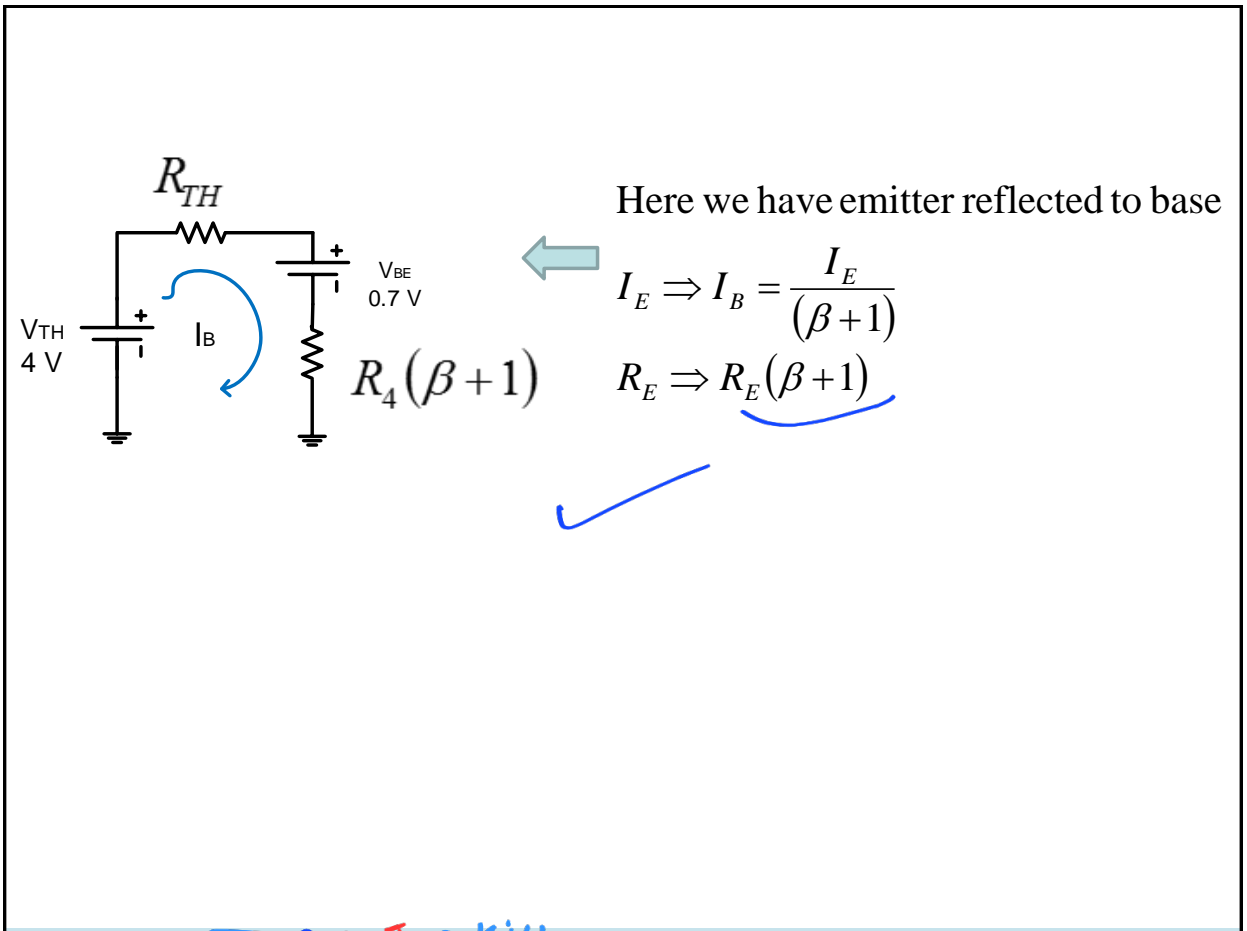

ac ss eq. circuit
 to find A_v, A_i, Z_i, Z_o

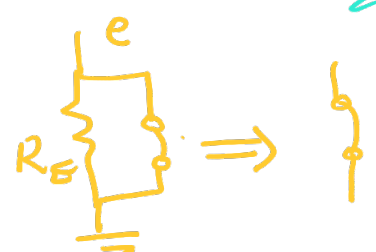

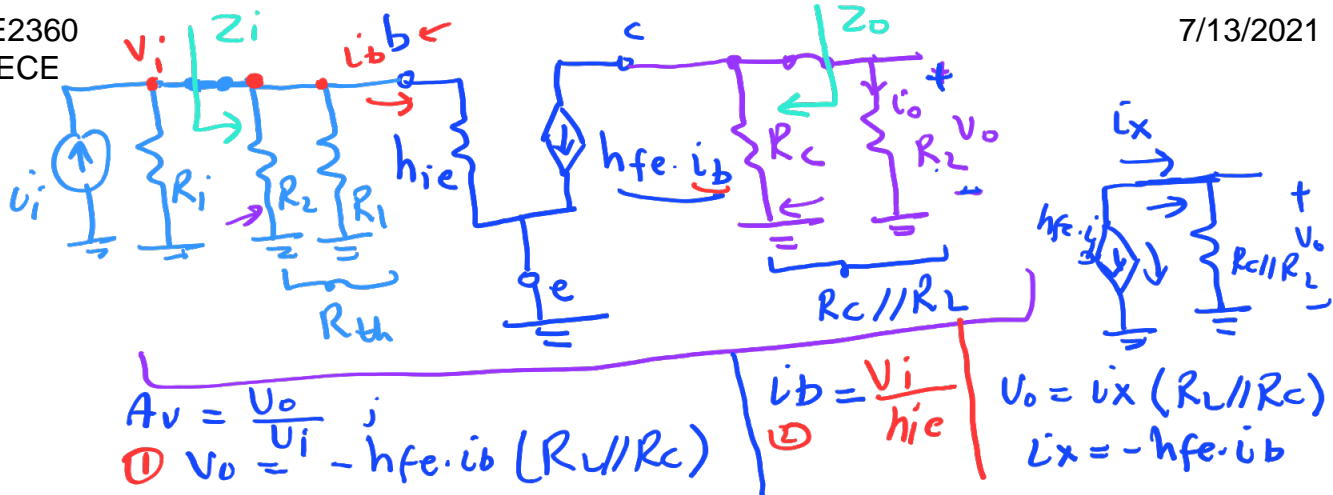

AC small signal Equivalent Circuit

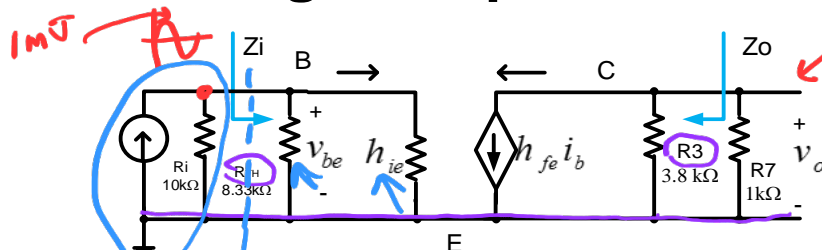

1) $A_v = \frac{v_o}{v_i}$

$A_v = \frac{v_o}{v_i} = \frac{v_o}{i_b} \cdot \frac{i_b}{v_i}$

① $v_o = -h_{fe} i_b \cdot (R_3 // R_7)$ \rightarrow $= -h_{fe} \cdot (R_3 // R_7) \cdot \left(\frac{1}{h_{ie}} \right)$

② $i_b = \frac{v_i}{h_{ie}}$ \rightarrow $= -50 \cdot (3.8 \text{ k}\Omega // 1 \text{ k}\Omega) \cdot \left(\frac{1}{928 \Omega} \right) = -42.7$

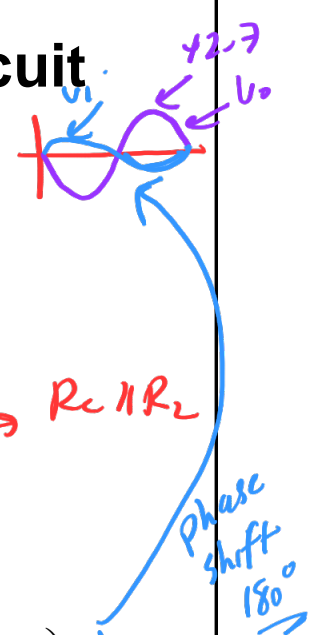

$R_C // R_L$

AC small signal Equivalent Circuit

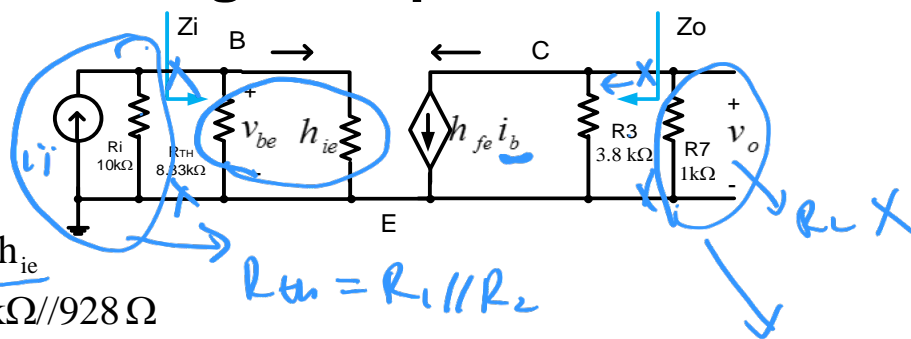

$$2) Z_I = R_{TH} // h_{ie} \\ = 8.33 \text{ k}\Omega // 928 \Omega$$

$$R_{th} = R_1 // R_2$$

only elements to the right of arrow are considered

according to the given direction of the arrow

$$3) Z_o \Big|_{\text{all independent sources killed (i.e. } v_i=0 \text{ or short)}} = 3.8 \text{ k}\Omega$$

here $h_{fe} \cdot i_b = 0$ since $i_b = 0$ ($v_i = 0$ - killed)

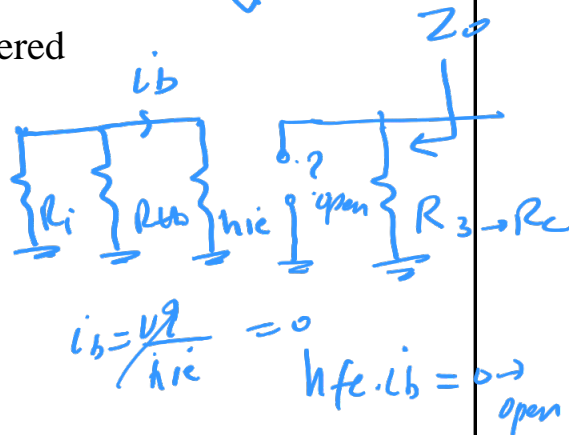

AC small signal Equivalent Circuit

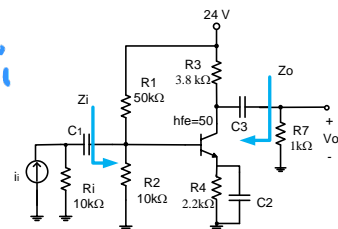

ac ss
current gain

$$\frac{v_b}{i_i} \times \frac{i_o}{v_b} = \frac{i_o}{i_i} = A_i$$

4) $A_i = \frac{i_o}{i_i}$

1) $i_b = (i_i) \left(\frac{R_1 // R_{TH}}{(R_1 // R_{TH}) + h_{ie}} \right)$

2) $i_o = -h_{fe} i_b \left(\frac{R_3}{R_3 + R_7} \right)$

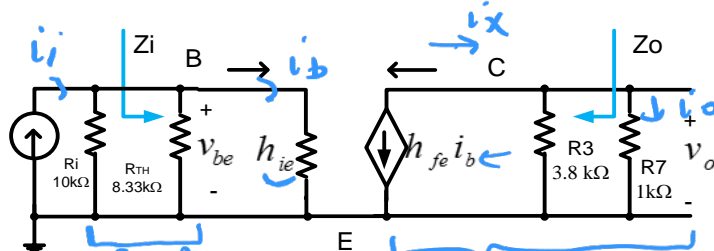

$i_o = i_x \frac{R_3}{R_3 + R_7}$

$A_i = \frac{i_o}{i_i} = \frac{i_o}{i_b} \cdot \frac{i_b}{i_i} = -h_{fe} \left(\frac{R_3}{R_3 + R_7} \right) \left(\frac{R_1 // R_{TH}}{(R_1 // R_{TH}) + h_{ie}} \right) = \underline{\underline{-33}}$ $i_x = -h_{fe} \cdot i_b$

$i_b \Rightarrow i_e ?$

$i_e = (\beta + 1) i_b$

$i_b = \frac{i_e}{\beta + 1}$

Reflection \rightarrow simplification technique
 From Emitter to base
 Base to Emitter
 or "

Impedance Reflection Concept

v1, v2, v3 are all ac sources

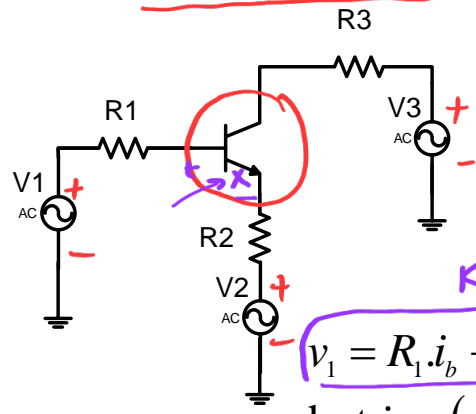

KVL

$$v_1 = R_1 i_b + h_{ie} i_b + R_2 i_e + v_2$$

but $i_e = (\beta + 1) i_b$

$$v_1 = R_1 i_b + h_{ie} i_b + R_2 (\beta + 1) i_b + v_2$$

ac ss equivalent circuit

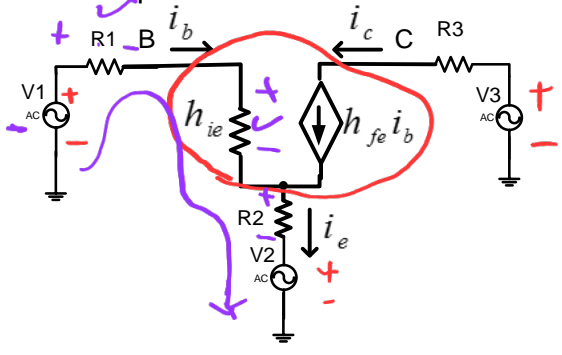

$$i_b = \frac{v_1 - v_2}{R_1 + h_{ie} + R_2 (\beta + 1)}$$

\leftarrow base loop equivalent circuit equation

$\beta = h_{fe}$

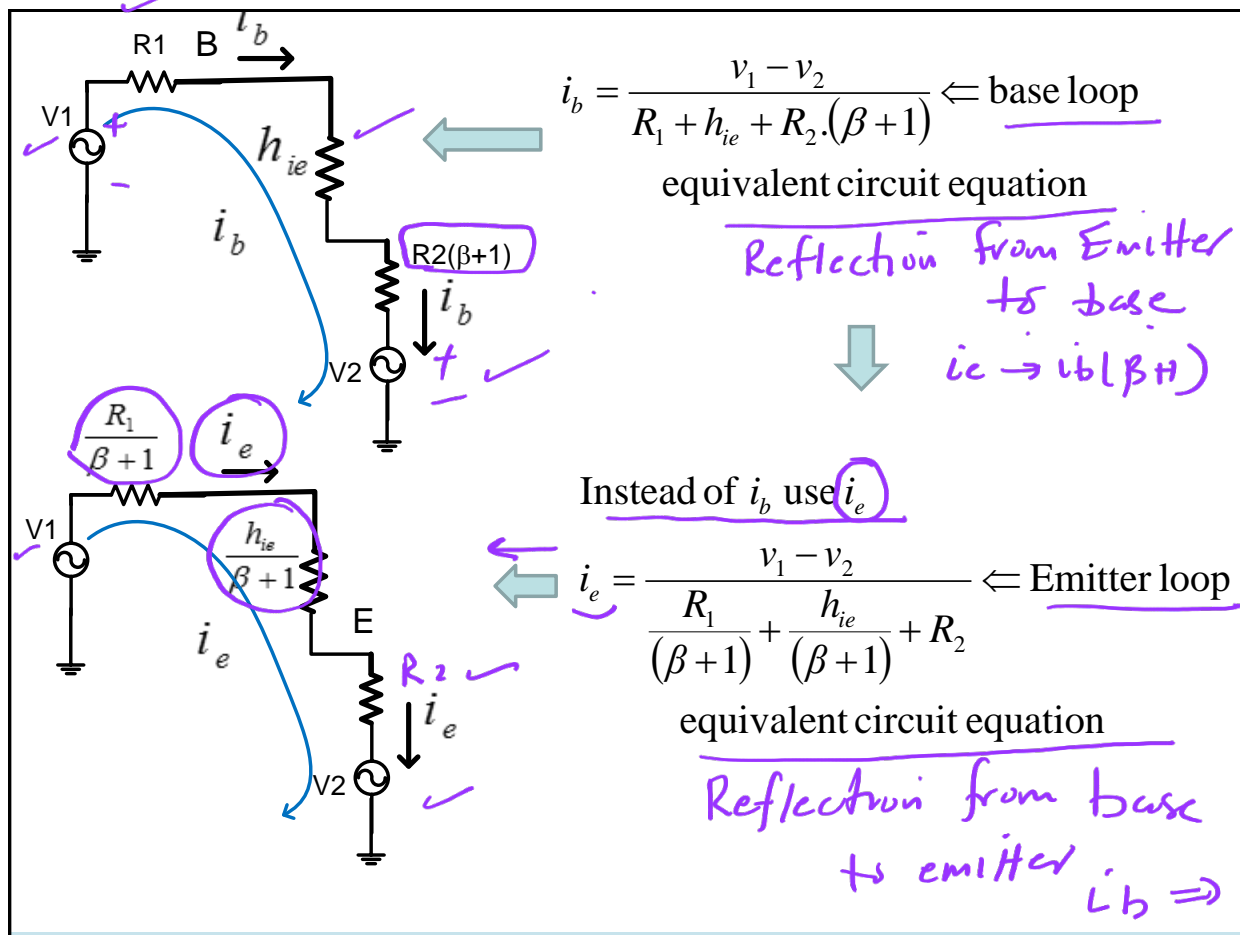

Please read

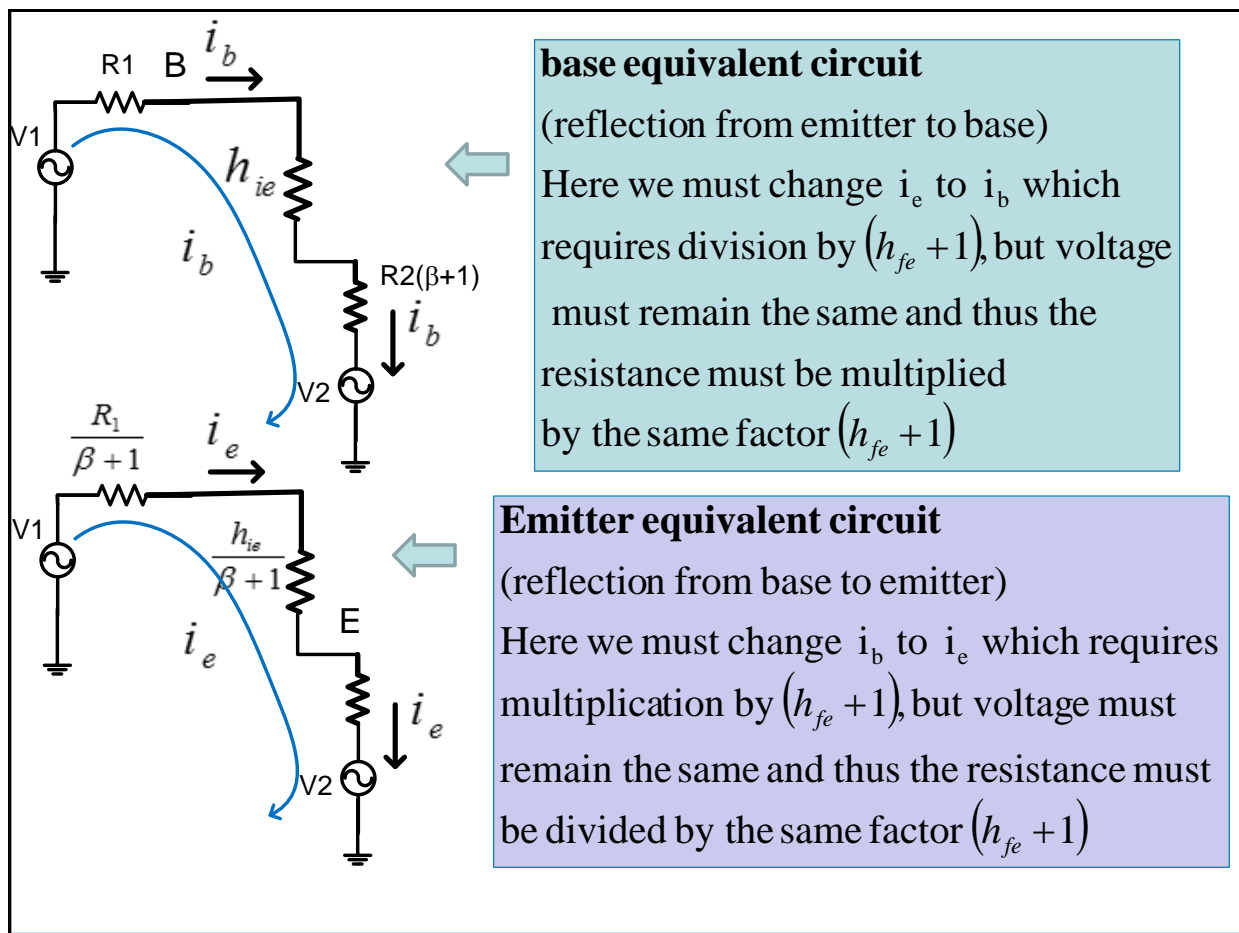

Collector Equivalent Circuit

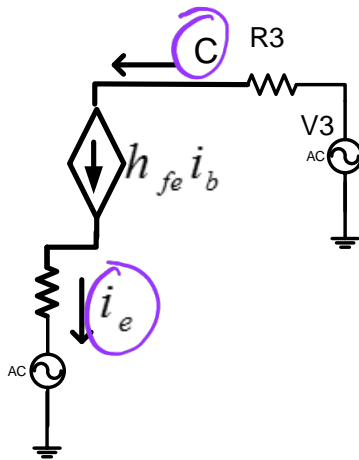

Note: there is no reflection from emitter to collector or vice versa since the i_e and i_c are almost the same

* * *
↖ ↗

Common Collector Amplifier

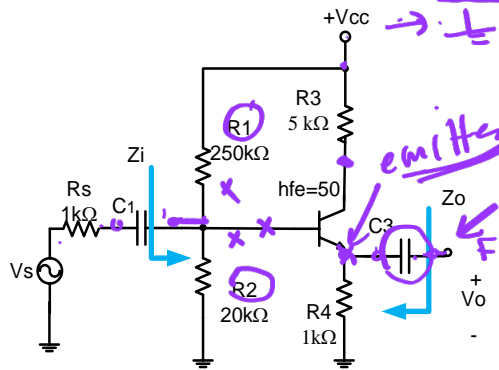

Given

$$h_{ie} = 1k\Omega$$

$$h_{fe} = \beta = 50$$

Find A_v, A_i, Z_i, Z_o

AC small signal Equivalent Circuit

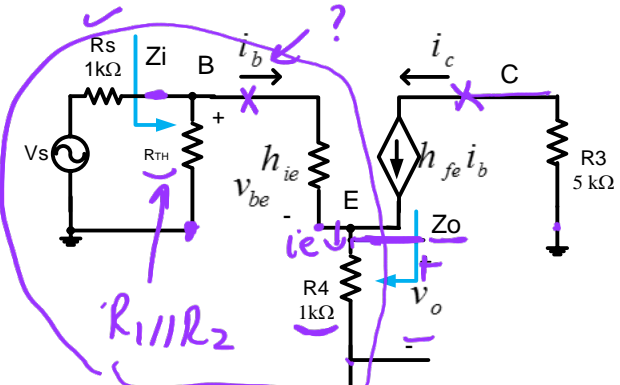

$$1) A_v = \frac{v_o}{v_s}$$

$$v_o = 1k\Omega \cdot i_e$$

$$i_e = i_b (h_{fe} + 1)$$

①

②

ac ss eq. circuit

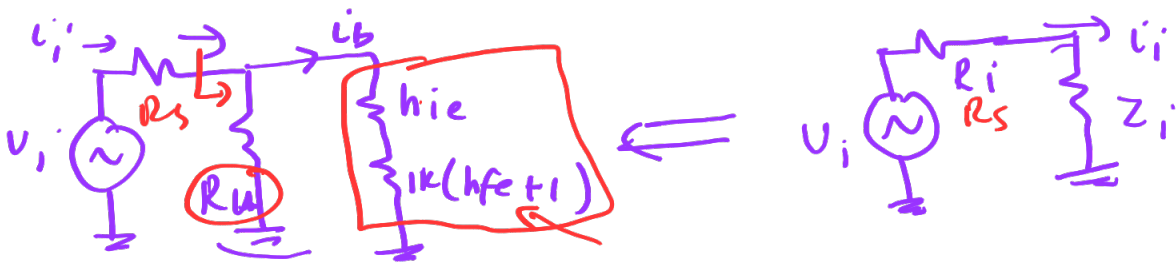

$$i_i = \frac{V_i}{Z_i + R_i}$$

i_b can be found from base equivalent circuit

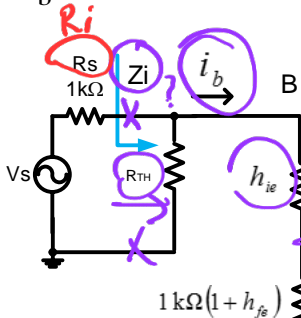

$$R_{TH} = 20 \text{ k}\Omega // 250 \text{ k}\Omega$$

$$i_b = i_i \frac{R_{TH}}{(R_{TH}) + (h_{ie} + 1 \text{ k}\Omega(h_{fe} + 1))} \quad (3)$$

$$i_i = \frac{V_S}{R_S + (R_{TH} // (h_{ie} + 1 \text{ k}\Omega(h_{fe} + 1)))} \quad (4)$$

$$\therefore A_v = \frac{v_o}{v_s} = \frac{v_o}{i_e} \cdot \frac{i_e}{i_b} \cdot \frac{i_b}{i_i} \cdot \frac{i_i}{v_s} =$$

$$= (1 \text{ k}\Omega) \cdot (h_{fe} + 1) \left(\frac{R_{TH}}{(R_{TH}) + (h_{ie} + 1 \text{ k}\Omega(h_{fe} + 1))} \right) \left(\frac{1}{R_S + (R_{TH} // (h_{ie} + 1 \text{ k}\Omega(h_{fe} + 1)))} \right)$$

$$= 0.915 < 1$$

cc amplifier doesn't provide any voltage gain
 $A_v \leq 1$

2) $A_i = \frac{i_o}{i_i}$

$i_o = \frac{v_o}{1\text{ k}\Omega}$ ✗

$i_o = i_e = i_b(h_{fe} + 1)$ ✓

$i_b = i_i \frac{R_{TH}}{(R_{TH}) + (h_{ie} + 1\text{ k}\Omega)(h_{fe} + 1)}$ ✓

$A_i = \frac{i_o}{i_i} = \frac{i_o}{i_e} \cdot \frac{i_e}{i_b} \cdot \frac{i_b}{i_i}$

$= 1(h_{fe} + 1) \left(\frac{R_{TH}}{R_{TH} + [h_{ie} + 1\text{ k}(h_{fe} + 1)]} \right) = 13.39 > 1$

$$3) Z_i = (R_{TH} // (h_{ie} + 1k\Omega(h_{fe} + 1)))$$

$$= 13.66 k\Omega \text{ (high)}$$

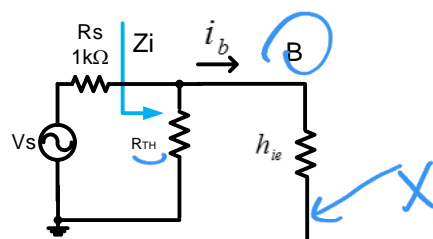

Emitter Equivalent Circuit
& $V_s = 0$

$$Z_o|_{V_s=0} = \left(\frac{(R_S // R_{TH}) + h_{ie}}{(h_{fe} + 1)} // 1k\Omega \right)$$

$$= \left(\left(\left(\frac{R_S}{(h_{fe} + 1)} // \frac{R_{TH}}{(h_{fe} + 1)} \right) + \frac{h_{ie}}{(h_{fe} + 1)} \right) // 1k\Omega \right)$$

$$= 36.8 \Omega \text{ (low)}$$

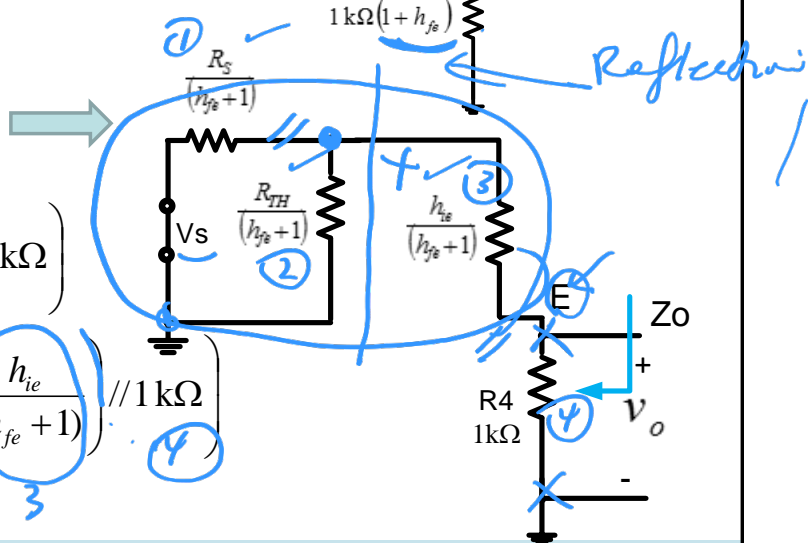

cc amplifier

$A_v \leq 1$
 $A_i \gg 1$
 $Z_i \uparrow \uparrow$
 $Z_o \downarrow \downarrow$

End of L14

L15
5/18/2021
←
see separate pdf
file

CC Amplifier as a Buffer

- The value of load resistor R_L affects the voltage gain A_v ,
- This effect is called loading effect and can be substantial

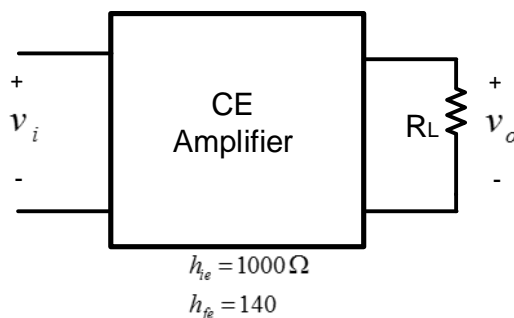

- A buffer (interface) can be used between the amplifier and the load to reduce this loading effect and keep the high gain
- CC Amplifier is also known as Emitter Follower

CC Amplifier as a Buffer

- The buffer must have the following characteristic:
 - $A_V \approx 1$
 - $A_I > 1$
 - $Z_I \gg \text{high}$
 - $Z_o \ll \text{low}$
- The above characteristic are present in the CC amplifier the load to reduce this loading effect and keep the high gain

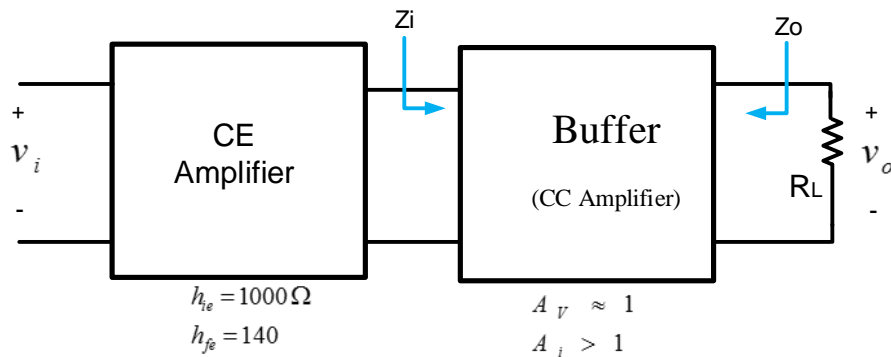

Example

- First we consider effect of load (R_L) on amplifier voltage gain
- Then we use a buffer and see its effect on reducing effect of R_L

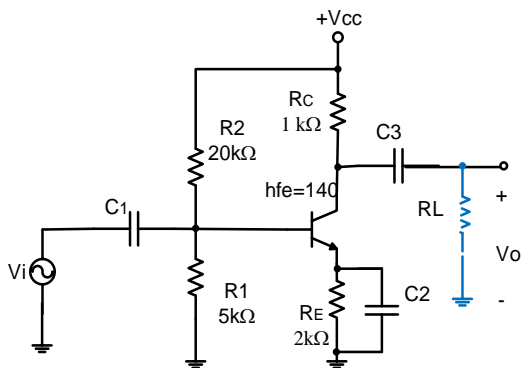

1) with $R_L = \infty$

$$v_o = -h_{fe} i_b \cdot (R_C)$$

$$i_b = \frac{v_i}{h_{ie}}$$

$$A_V = \frac{v_o}{v_i} = (-h_{fe} R_C) \cdot \frac{1}{h_{ie}} = -140$$

2) with $R_L = 50 \Omega$

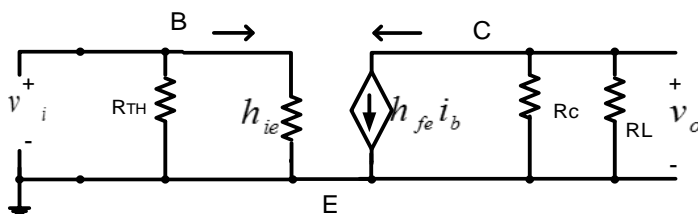

$$A_V = \frac{v_o}{v_i} = (-h_{fe} R_C // R_L) \cdot \frac{1}{h_{ie}} = -6.87$$

A_V have been reduced from -140 to -6.87

Amplifier + Buffer + Load

Now let us look at the new circuit with the buffer

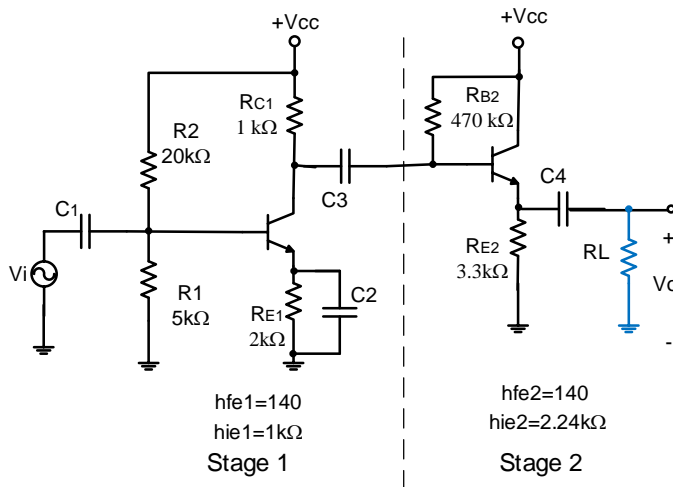

ac ss equivalent Circuit

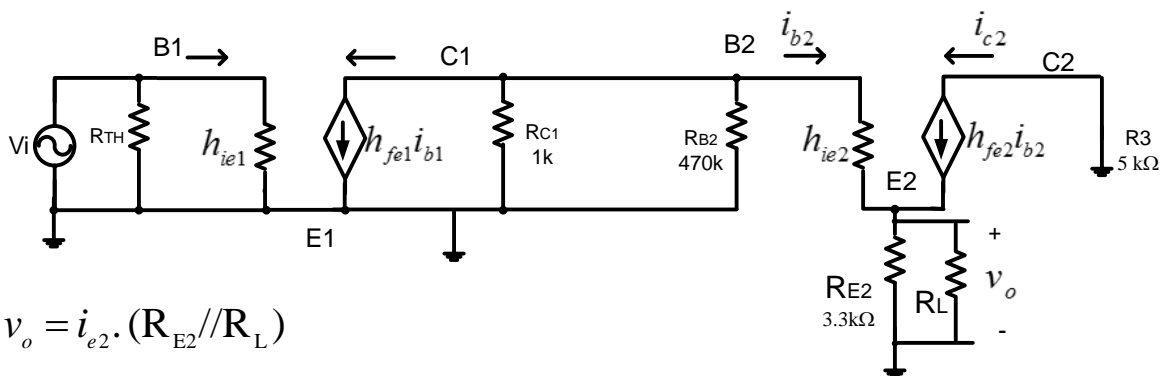

$$v_o = i_{e2} \cdot (R_{E2} // R_L)$$

$$i_{e2} = i_{b2} (1 + h_{fe2})$$

$$i_{b2} = -h_{fe1} \cdot i_{b1} \frac{(R_{C1} // R_{B2})}{((R_{C1} // R_{B2}) + (h_{ie2} + (R_{E2} // R_L)(1 + h_{fe2})))}$$

$$i_{b1} = \frac{V_i}{h_{ie1}}$$

$$\Rightarrow Av = \frac{v_o}{v_i} = \frac{v_o}{i_{e2}} \cdot \frac{i_{e2}}{i_{b2}} \cdot \frac{i_{b2}}{i_{b1}} \cdot \frac{i_{b1}}{v_i} = -95.6$$

This is much better than the case without buffer

Multistage Amplifiers

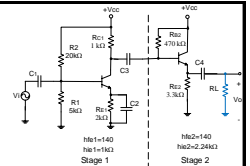

- The previous example of a CE amplifier with a CC buffer is an example of a multistage amplifier (two-stage amplifier)
- Multistage amplifiers can be used to get more gain and to improve the performance of the amplifier
- These amplifiers such that the Output of first stage is connected to input of second stage
- Capacitor C3 is a decoupling capacitor that separates the two stages for DC bias point stability, this makes the two stages completely separate in DC analysis and their Q-points are not affected by each other
- C2 is used as a bypass capacitor for stage 1 and allows stabilization of the Q-point, if C2 is removed the input impedance of the amplifier can be improved

Cascaded Systems

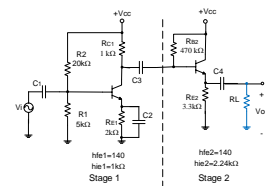

- The output of one amplifier is the input to the next amplifier
- The overall voltage gain is determined by the product of gains of the individual stages
- The DC bias circuits are isolated from each other by the coupling capacitors
- The DC calculations are independent of the cascading
- The AC calculations for gain and impedance are interdependent

R-C Coupled BJT Amplifiers

Voltage gain:

$$A_v = A_{v1} A_{v2}$$

Input impedance,
 first stage:

$$Z_i = R_1 \parallel R_2 \parallel h_{ie1}$$

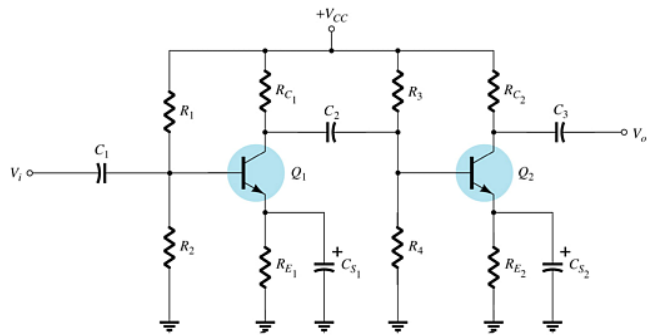

Output impedance,
 second stage:

$$Z_o = R_C$$

Darlington Connection

- The Darlington circuit provides very high current gain, equal to the product of the individual current gains:

$$\bullet \beta_D = \beta_1 \beta_2$$

- The practical significance is that the circuit provides a very high input impedance.

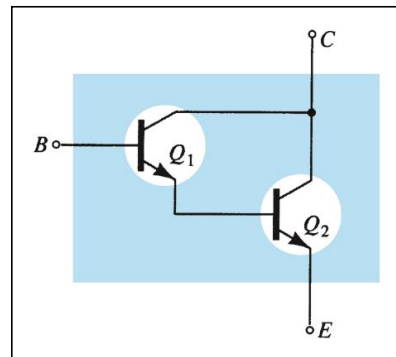

DC Bias of Darlington Circuits

Base current: $I_{BD} = I_{B1} = \frac{V_{CC} - V_{BED}}{R_B + (\beta_D + 1)R_E}$

Emitter current: $I_{ED} = I_{E2}$

$$I_{E2} = I_{B2}(\beta_2 + 1)$$

$$I_{B2} = I_{E1}$$

$$I_{E1} = I_{B1}(\beta_1 + 1)$$

$$I_{E2} = I_{B1}(\beta_2 + 1)(\beta_1 + 1)$$

$$I_{ED} = \beta_D I_{BD}$$

Emitter voltage: $V_E = I_{ED} R_E$

Base voltage: $V_B = V_E + V_{BE}$
 $V_{BED} = V_{BE1} + V_{BE2} \cong 1.4 \text{ V}$

KVL for input loop :
 $V_{CC} - I_{B1} R_B - V_{BE1} - V_{BE2} - I_{E2} R_E = 0$

$$V_{CC} - I_{BD} R_B - V_{BED} - I_{ED} R_E = 0$$

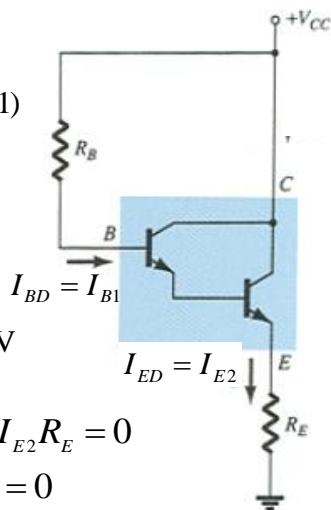

Darlington Pair

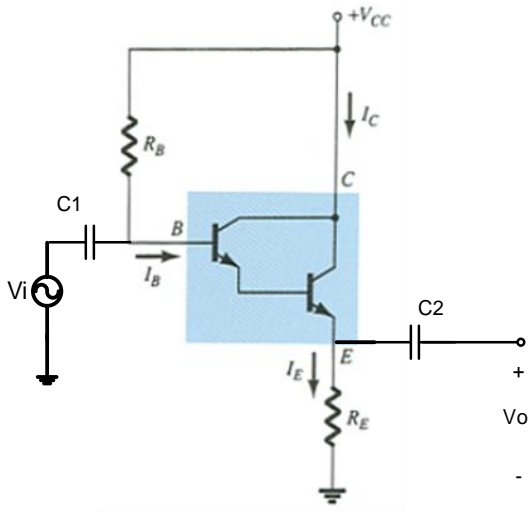

Find Ratio of $\frac{i_{e2}}{i_{b1}}$ and A_v

$$i_{e2} = i_{b2}(h_{fe2} + 1)$$

$$i_{b2} = i_{e1}$$

$$i_{e1} = i_{b1}(h_{fe1} + 1)$$

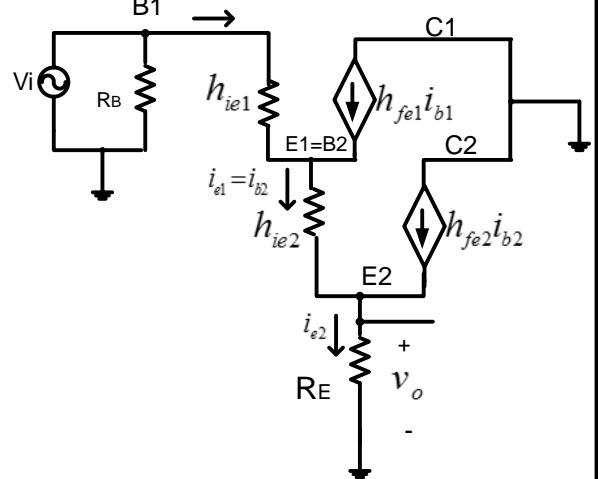

$$i_{e2} = i_{b1}(h_{fe1} + 1)(h_{fe2} + 1)$$

$$i_{ed} = h_{fed}i_{bd}$$

$$h_{fed} = (h_{fe1} + 1)(h_{fe2} + 1)$$

$$\cong h_{fe1}h_{fe2}$$

$$\cong h_{fe}^2, \text{ (if } h_{fe1} = h_{fe2} = h_{fe} \text{)}$$

2) Find $A_v = \frac{v_o}{v_i}$

$v_o = i_{e2} R_E$

$i_{e2} = i_{b1} (h_{fe1} + 1)(h_{fe2} + 1)$

$i_{b1} = \frac{v_i}{Z_i}$

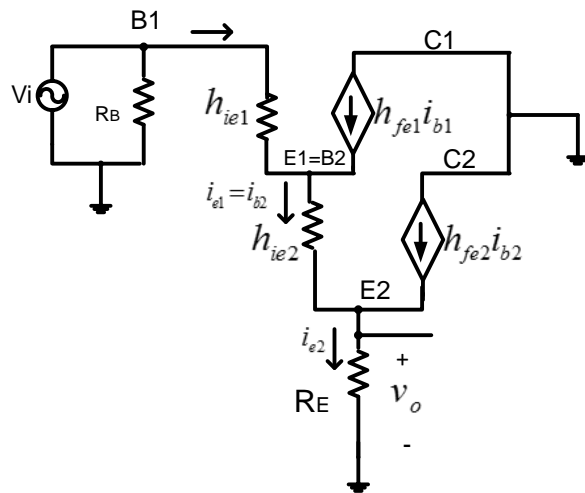

3) Find Z_i
 base equivalent circuit is needed

$h_{ie2} \Rightarrow h_{ie2}((h_{fe1} + 1))$ since it is reflected from emitter1 to base1

$R_E \Rightarrow R_E(h_{fe1} + 1)(h_{fe2} + 1)$ since it is reflected twice

1) From E2 to B2 (B2 = E1)
 2) From E1 to B1

$$\Rightarrow Z_i = h_{ie1} + h_{ie2}(h_{fe1} + 1) + R_E(h_{fe1} + 1)(h_{fe2} + 1)$$

4) Find $Z_o|_{V_s=0}$

Zo

Emitter equivalent circuit is needed

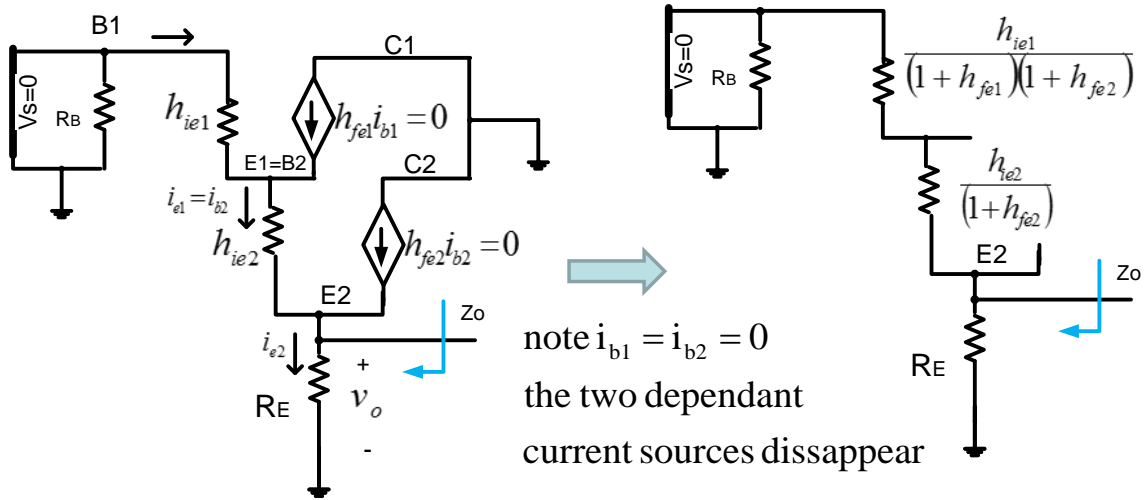

$$Z_o = \left(\frac{h_{ie1}}{(h_{fe1} + 1)(h_{fe2} + 1)} + \frac{h_{ie2}}{(h_{fe2} + 1)} \right) // R_E$$

Darlington Simplified Model

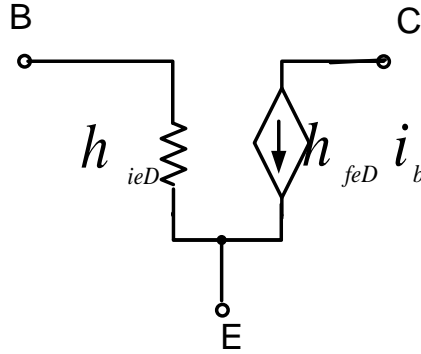
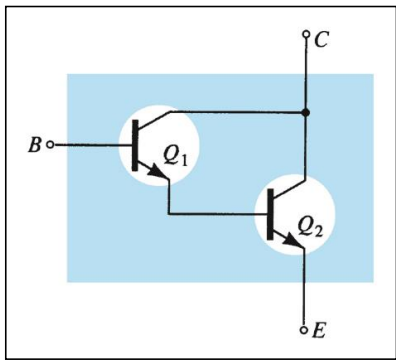

$$h_{ieD} \cong 2h_{ie}$$

$$h_{feD} \cong h_{fe1} \cdot h_{fe2}$$

Base To Collector Feedback

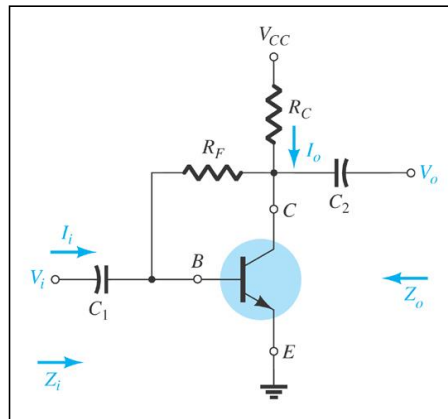

Exercise : Find A_v , Z_i and Z_o

Base To Collector Feedback

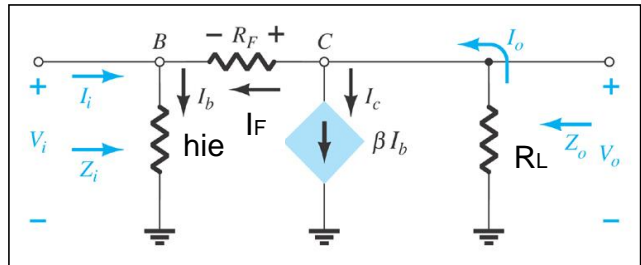
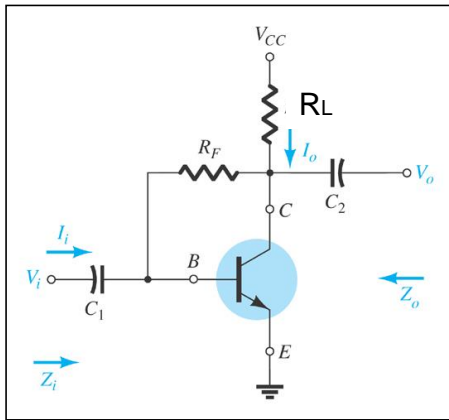

Exercise : Find A_v , Z_i and Z_o

Base To Collector Feedback

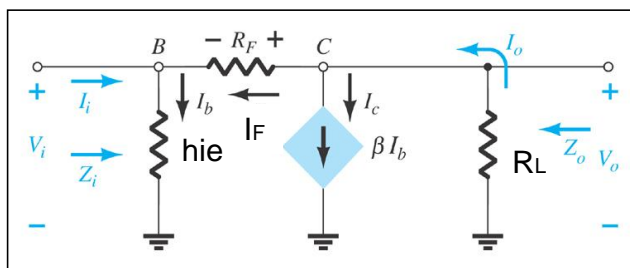
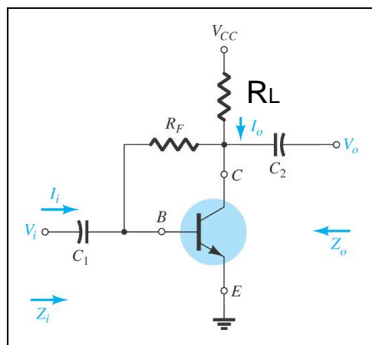

$$v_o = -i_o \cdot R_L$$

$$i_o = h_{fe} \cdot i_b + i_F$$

$$i_F = \frac{v_o - v_i}{R_F}$$

$$i_b = \frac{v_i}{h_{ie}}$$

$$v_o = - \left(h_{fe} \cdot \frac{v_i}{h_{ie}} + \frac{v_o - v_i}{R_F} \right) \cdot R_L$$

$$v_o = -R_L h_{fe} \cdot \frac{v_i}{h_{ie}} - \frac{v_o R_L}{R_F} + \frac{v_i R_L}{R_F}$$

$$v_o \left(1 + \frac{R_L}{R_F} \right) = v_i \left(\frac{R_L}{R_F} - R_L \cdot \frac{h_{fe}}{h_{ie}} \right)$$

$$A_v = \frac{\left(\frac{R_L}{R_F} - R_L \cdot \frac{h_{fe}}{h_{ie}} \right)}{\left(1 + \frac{R_L}{R_F} \right)}$$

$$Z_0|_{v_i=0} = R_F // R_L$$

$$Z_i = \frac{V_i}{i_i}$$

$$i_i = i_b - i_F = \left(\frac{v_i}{h_{ie}} - \frac{v_o - v_i}{R_F} \right)$$

$$Z_i = \frac{V_i}{i_i} = \frac{V_i}{\left(\frac{v_i}{h_{ie}} - \frac{v_o - v_i}{R_F} \right)}$$

$$= \frac{V_i}{\left(\frac{R_F v_i - h_{ie} (v_o - v_i)}{R_F h_{ie}} \right)}$$

$$= \frac{v_i R_F h_{ie}}{(R_F v_i - h_{ie} (v_o - v_i))}$$

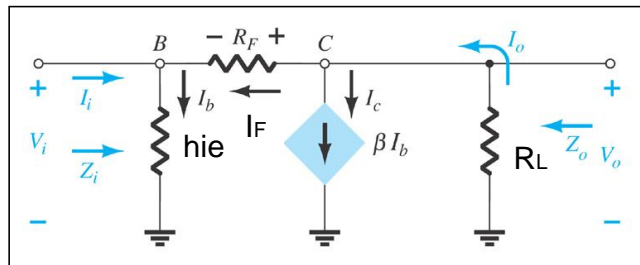

$$= \frac{v_i R_F h_{ie}}{((R_F + h_{ie})v_i - h_{ie}v_o)}$$

$$= \frac{R_F h_{ie}}{\left((R_F + h_{ie}) - h_{ie} \frac{v_o}{v_i} \right)}$$

$$= \frac{R_F h_{ie}}{((R_F + h_{ie}) - h_{ie} A_v)}$$